



**AUSSIE**  
GREEN LIGHTING

Unit 10/78 Willandra Drive Epping Vic 3076 | 03 9401 4885 |

E-mail: [info@aussiegreenlighting.com.au](mailto:info@aussiegreenlighting.com.au) |

Web: [www.aussiegreenlighting.com.au](http://www.aussiegreenlighting.com.au)

# LED Flood Light | 75W



Built-in sensor

## Advantages

- High efficiency, 140lm/w available.
- Beam angle 30° /60° /90° /120° / T2M/ T3M
- Integrated die-casting aluminum housing, elegant appearance
- Good heat dissipation, long lifespan
- Tempered glass, surface coating process, excellent corrosion-proof
- IP66



# DISTANCE

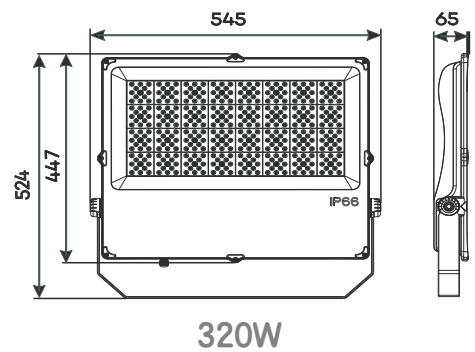
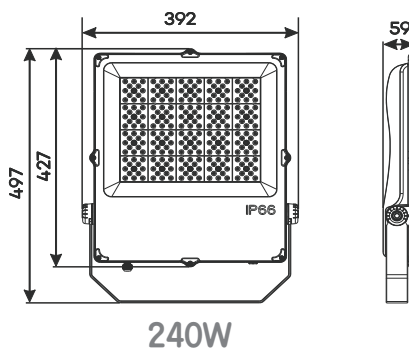
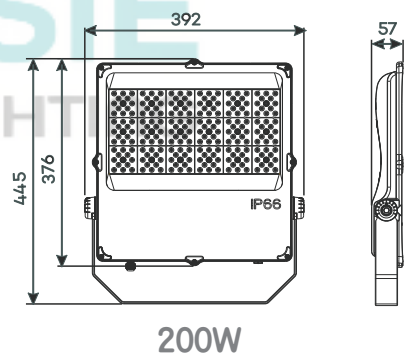
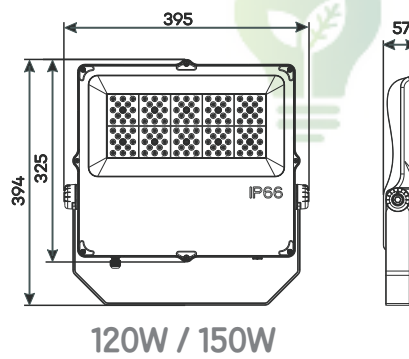
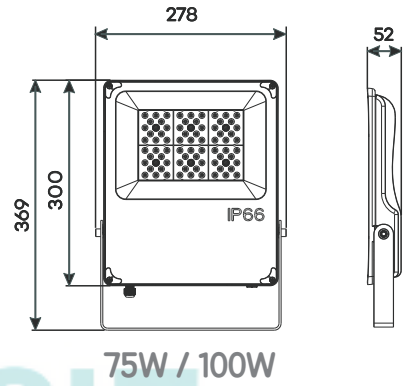
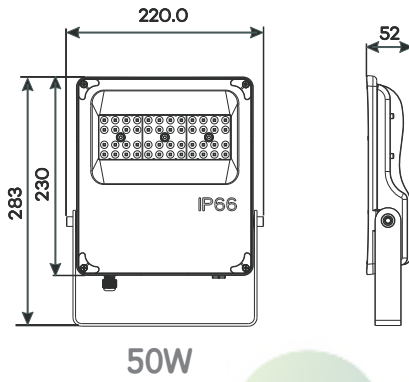
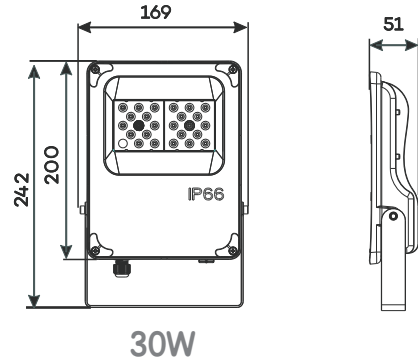
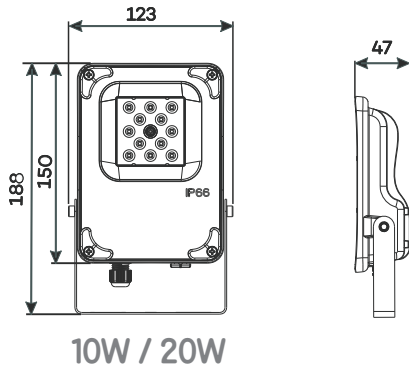

## APPLICATION

- Billboard
- Road
- Tunnel
- Bridge and culvert
- Square
- Building



AUSSIE  
GREEN LIGHTING



## SPECIFICATIONS

Item No	ERS-F75W
Power	75W
Efficiency	140lm/w
Lumen	10500lm
Input Voltage	AC220~240V,50Hz
CCT	3000K-6500K
IP Rating	IP 66
Beam Angle	30° /60° /90° /120° /T2M/T3M
Power Factor	>0.9
CRI	Ra>80
LED Chips	Lumileds 3030
Driver	ERS driver
Sensor	Daylight&Microwave Motion Sensor
Dimmable	PWM
Total Harmonic Distortion (THD)	≤15%
Power Supply Efficiency	>90%
Product Size (mm)	369X278X52



**AUSSIE**  
GREEN LIGHTING

# INSTALLATION

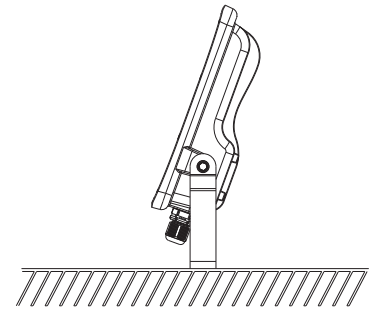
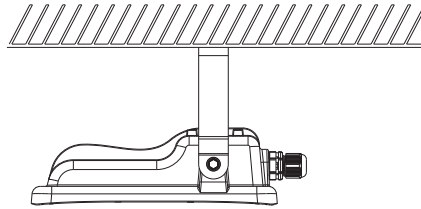
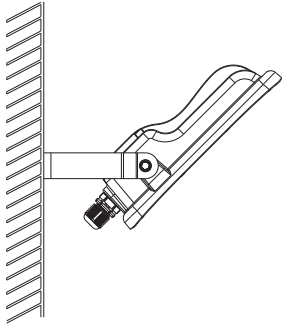

1. Fix the bracket on the wall by screws
2. Adjust the lamp body to proper orientation
3. Fix the screws that connecting the bracket and the lamp body.
4. Connect the wires. Brown wire is L, blue wire is N, and yellow-green wire is G.



# AUSSIE

## DISTRIBUTION CURVE FLUX GREEN LIGHTING

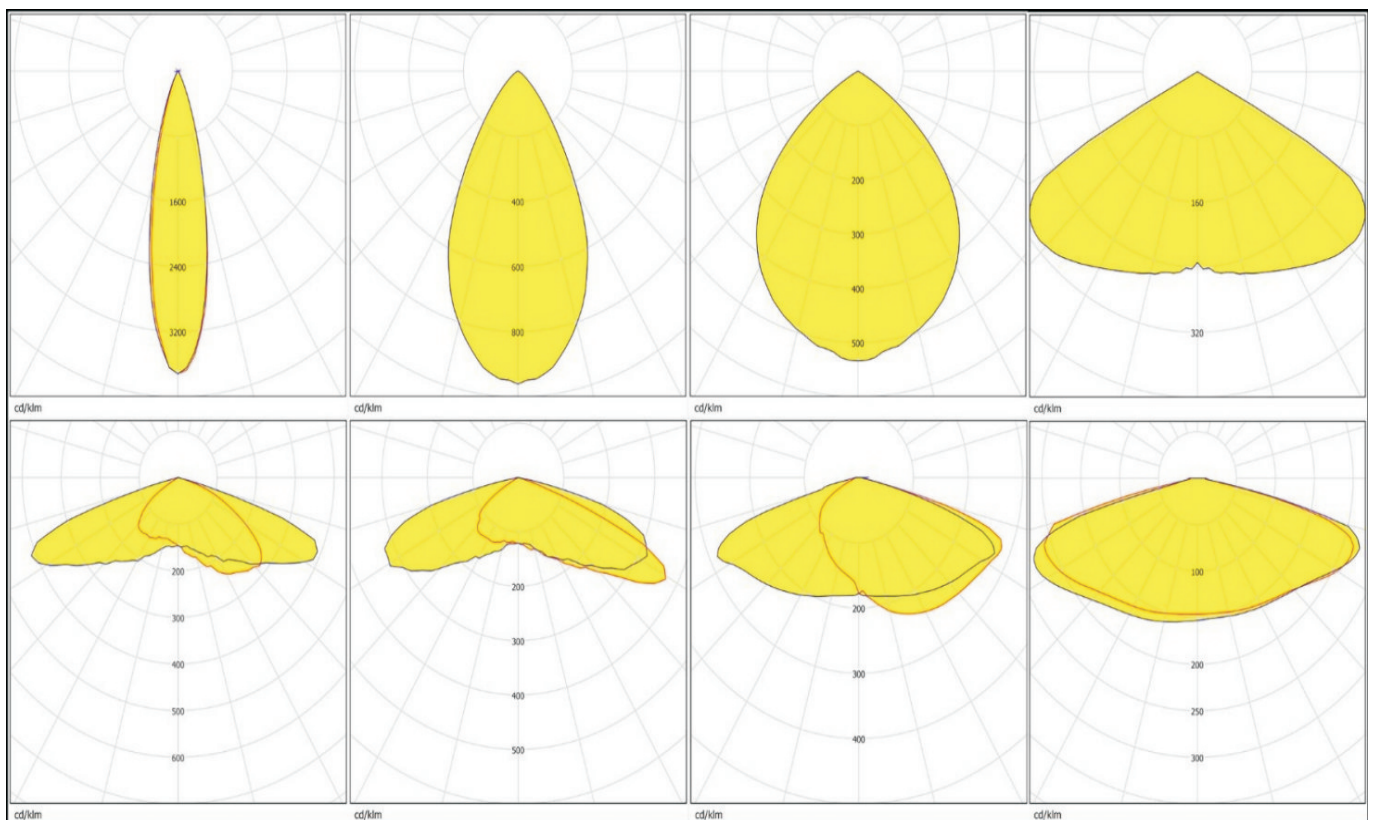

# LUMINOUS INTENSITY DISTRIBUTION

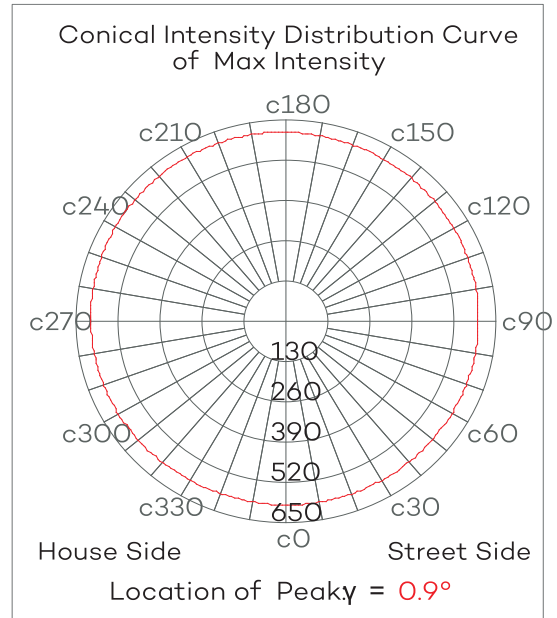
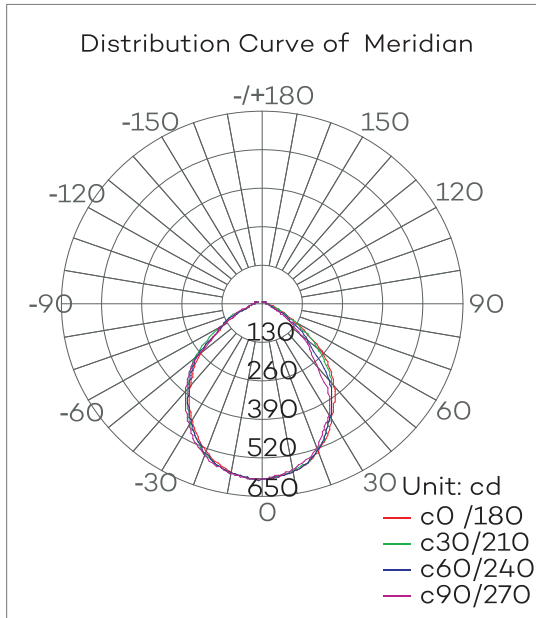

## Illumination Cone Curve

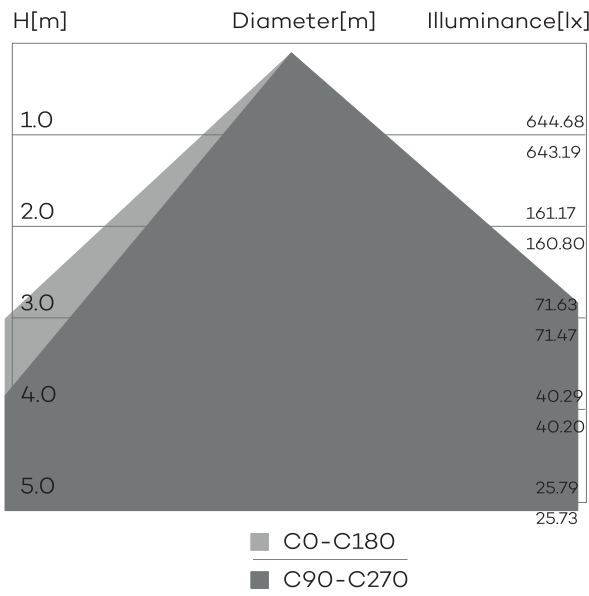

## PACKING

Item code	Carton Size (mm)		N.W.(KG)	G.W.(KG)
ERS-F10/20W	306X205X265	10	7	10
ERS-F30W	400X260X280	10	12	14
ERS-F50W	500X330X245	8	14.8	17.7
ERS-F75/100W	415X315X365	6	16	19.6
ERS-F120/150W	492X492X80	1	4.28	5.7
ERS-F200W	530X492X80	1	4.82	6.5
ERS-F240W	585X492X80	1	6.1	8.1
ERS-F320W	614X645X85	1	9	11.5



## FUNCTION DEMO-ON/OFF CONTROL

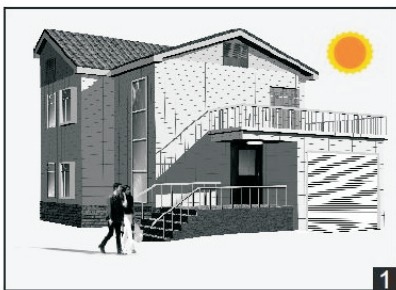

With insufficient daylight,even when motion detected,light remains OFF.



With insufficient daylight,even when motion detected,light ON.



After the last detection and the present hold time elapsed,light OFF.

## REMOTE CONTROLLER

Factory setting: When turn on the Flood light, sensor function is closed;  
if you need to open the sensor, please use our remote controller as below.  
Sensor default setting: daylight (OFF), motion(2 seconds), hold time (2 seconds),  
standby brightness 0%.

**D:** Press one time, Daylight Sensor working only.

**On:** Press one time, work with default setting.

**Sc1:** Hold on 30 minutes and then dimming down to its 50% luminosity. Daylight Sensor OFF.

**Sc2:** Hold on 10 minutes and then dimming down to its 20% luminosity. Daylight Sensor OFF.

**M:** Press one time, Motion Sensor working only.

Record the current environment lux.

**Sc3:** Hold on 30 seconds and then turn OFF. Daylight Sensor OFF.



# SENSOR SPECIFICATION

## Detection Patterns

## Technical data

Operating voltage	12VDC $\pm$ 2v
Stand-by power	< 1W
Operating temperature	-20°C ~ +60°C
Detection area	100%/75%/50%/20%
Hold time	2Sec/30Sec/60Sec/2Min/5Min/15Min/30Min/60Min
Daylight threshold	5Lux/25Lux/50Lux/100Lux/300Lux/600Lux/Disable
Microwave power	< 1mW
Microwave frequency	5.8GHz $\pm$ 75MHz
Mounting height	Max.12m(ceiling mounted)
Detection range	Diameter 14m (ceiling mounted)
Type	Built-in

Note: Sensor setting please refer to remote control

